



Microlift
material handling -solution

T15i/T20i/T25i i-Hybrid

Your Intelligent Work Partner

Electric & Manual Mode Switch to Maximize Uptime

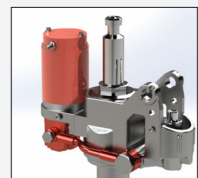

Electric Lift Mode
Easy and efficient



Manual Lift Mode
Extending uptime of
30 minutes
NO DOWNTIME



Brushless motor
Higher efficiency
Cost saving
FREE MAINTENANCE

Hybrid Pump

Hybrid Drive

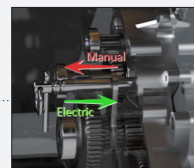

Patented Clutch Technology
Electric/Manual Mode convertible
NO DOWNTIME

OLED Screen
(Standard)



Display of running hour,
battery level, fault code
A single touch for Turtle
Mode & Upright Mode

I-Touch Screen
(Option)



2.5" hi-res touch screen
Efficient and intuitive
Interactive and customizable

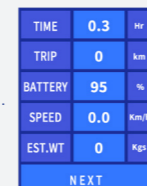

Digital display of mileage,
battery status,
travel speed,
approx. load weight



One-click VNA mode
Secure password setting
Displayable slope degree
Direct fault diagnosis

LFP Battery



T15i: 48V10Ah standard battery
T20i: 48V15Ah standard battery
T25i: 48V20Ah standard battery
Compact and portable
2-3 hrs fast charge
80% capacity after 2000 cycles

Specifications

T15i/T20i/T25i Electric Pallet Truck Parameter and Performance

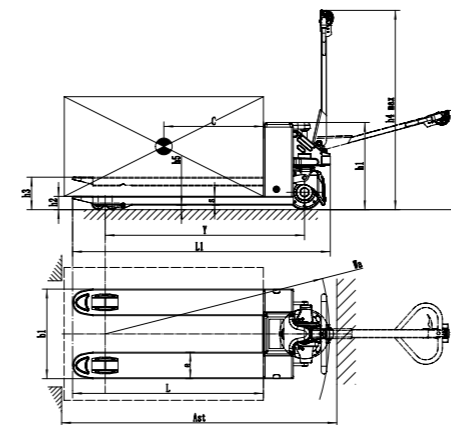

1	Manufacturer		Microlift		
2	Model		T15i	T20i	T25i
3	Drive Mode		Electric / Manual		
4	Lift Mode		Electric / Manual		
5	Operator Type		Pedestrian		
6	Load Capacity	Q	1500kg (3300lbs)	2000kg (4400lbs)	2500kg (5500lbs)
7	Load Center	C	600mm (24")		
8	Wheelbase	Y	1202mm/1272mm (47.3"/50.1")		
9	Service Weight		106/112kg (233/246lbs)	116/122kg (256/269lbs)	126.7/130.7kg (279/288lbs)
10	Overall Height	h1	587mm (23.1")		
11	Fork Height (Lowered)	h2	80mm (3.15")		
12	Lift Height	h3	200mm (8")		
13	Tiller Arm Height	h4	560mm-1280mm (22"-50.4")		
14	Ground Clearance	h5	27mm (1.1")		
15	Overall Length	L1	1546mm/1616mm (60.8"/63.6")		
16	Overall Width	b1	559mm/699mm (22" / 27.5")		
17	Fork Size	L	1150mm/1220mm (45"/48")		
		S	52mm (2.05")		
		e	160mm (6.3")		
18	Turning Radius (Min.)	Wa	1352mm/1422mm (53.2"/56")		
19	Aisle Width for Pallets 1000x1200 Crossways	AST	1980mm(78")		
20	Aisle Width for Pallets 800x1200 Crossways	AST	1880mm (74")		
21	Drive Motor		0.75kW Brushless	0.9kW	
22	Travel Speed (loaded/unloaded)		4.2/4.5km/h (2.6/2.8mph)		
23	Max. Gradeability (loaded/unloaded)		8%/20%	8%/20%	6%/20%
24	Service Brake		Electromagnetic		
25	Lift Motor		0.65kW		
26	Controller Manufacturer/Type		MICROLIFT i100	MICROLIFT i120	
27	Battery Voltage/Capacity		48V/10Ah LFP	48V/15Ah LFP	48V/20Ah LFP
28	Charger		48V/3A	48V/5A	

Remarks: Zhejiang Microlift Co., Ltd. reserves the right to make any changes without notice concerning specifications detailed in this brochure.

Highlights of T15i/T20i/T25i:

- ▶ Electric/Manual mode switch features **NO DOWNTIME**
- ▶ 8 hrs non-stop working with a spare battery
- ▶ 8% max. gradeability leads the market with superior performance
- ▶ Option: I-Touch Screen handle, Low profile, Scaled model, Galvanized model, Stainless Steel model, etc.

