

KOMATSU®

PC130-10M0

HYDRAULIC EXCAVATOR

PC130



Photos may include optional equipment.

HORSEPOWER

Gross: 72.6 kW 97.3 HP/2200 min⁻¹
Net: 69.7 kW 93.4 HP/2200 min⁻¹

OPERATING WEIGHT

12630 - 14410 kg

BUCKET CAPACITY

0.36 - 0.63 m³

WALK-AROUND

*Gives You the Higher Returns,
with Peace of Mind.*



HORSEPOWER

Gross: 72.6 kW 97.3 HP/2200 min⁻¹
Net: 69.7 kW 93.4 HP/2200 min⁻¹

OPERATING WEIGHT

12630 - 14410 kg

BUCKET CAPACITY

0.36 - 0.63 m³

PC130-10M10

Less Fuel & More Power

- *Reduction fuel consumption by 16%*
- *Improvement of engine combustion efficiency*
- *Reduction of hydraulic pressure loss*
- *Double pump to improve travel performance*
- *Large fuel tank to increase operating hour*

Durability & Reliability

- *Improve reliability under high temperature*
- *More durable cooling unit*
- *Enhanced work equipment*
- *Improve heat resistance of main valve O-ring*

Easy Maintenance

- *Less maintenance time with new features*
- *Detection system to prevent failure of main components*
- *More visible maintenance information on the monitor screen*

Safety & Comfort

- *Large comfortable cab*
- *ROPS Cab (ISO 10262)*
- *Rear view monitor system (Optional)*

Information & Communication Technology (ICT) & KOMTRAX

- *Large multi-lingual high resolution Liquid Crystal Display (LCD) monitor*
- *Equipment Management Monitoring System*
- *KOMTRAX*

LESS FUEL & MORE POWER

High Efficient Technology

The low speed matching of the engine and hydraulic system guarantee precision and low fuel consumption even engine power is increased. Through the in-house development and production of main components, Komatsu has achieved great advancements in technology, providing high levels of performance and efficiency in virtually all applications.

Fuel consumption

Reduced by **16%**

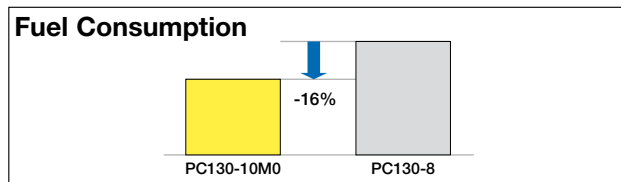

vs PC130-8

Fuel consumption is based on typical work pattern collected via KOMTRAX.

This fuel consumption data is the result that compared actual measured value by using the prototype machine.



Engine power

3% up (70 kW ← 68 kW)

Low Emission Engine

Komatsu SAA4D95LE-5 is equivalent EU Stage 3A emissions.

Improvement of engine combustion efficiency

By optimizing the fuel injection control, the engine combustion efficiency is improved. This technology achieved both high power output and low fuel consumption.

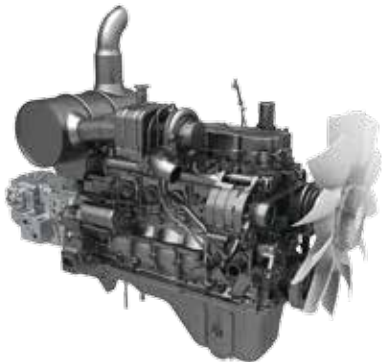

Reduction of hydraulic pressure loss

The internal shape of the control valves, piping diameter and fitting shape have been thoroughly revised. With this improvement, hydraulic loss is reduced more than ever. It contributes to low fuel consumption.

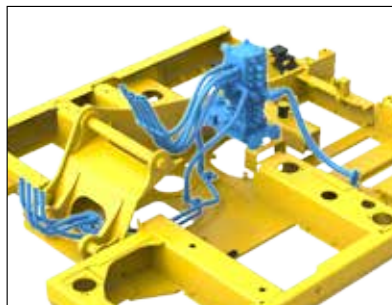

Enhanced engine-pump matching control

Large displacement hydraulic main pumps provide high flow output at low engine RPM. Furthermore, by building in optimum matching of the engine and pumps, it keeps high operability and workability. This technology achieved a large production and low fuel consumption.

ECO gauge

Equipped with the ECO gauge that can be recognized at a glance on the right of the multi-function color monitor for environment-friendly energy-saving operations. Allows focus on operation in the green range with reduced CO₂ emissions and efficient fuel consumption.

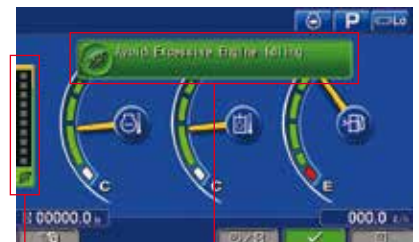

ECO gauge

Idling caution

Idling caution

To prevent unnecessary fuel consumption, an idling caution is displayed on the monitor, if the engine idles for 5 minutes or more.

Fuel Saving Support Functions

Just select a working mode that suits your purpose

In P mode, LARGE PRODUCTION is implemented. In E mode, LOW FUEL CONSUMPTION is implemented. E mode can be adjusted widely from E0 to E3 mode, and it adapts flexibly to customer's demands. Komatsu tuned each work mode precisely, ensuring high operability and workability. Just by selecting the work mode, it provides the best performance in demanding applications.

P (Power mode):

Maximum production
Fast cycle time

E (Economy mode):

Better fuel consumption

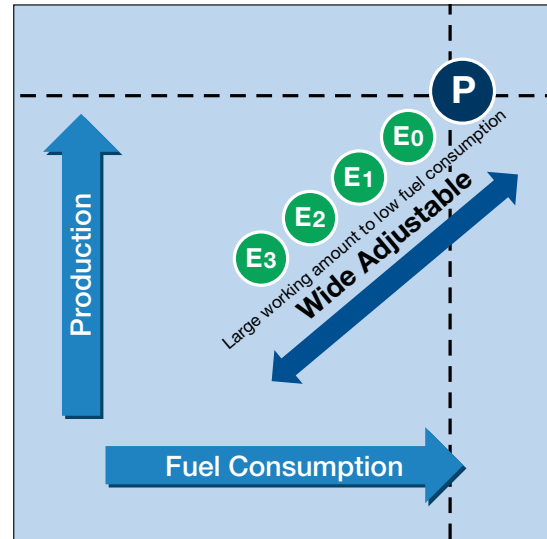

Easy selectable E mode

Compared with the conventional model, E0 to E3 can be easily selected on the monitor.

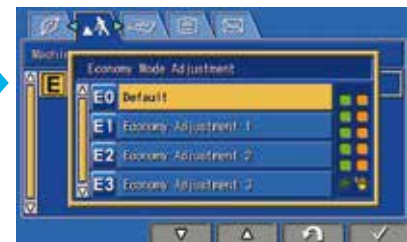

In addition to the above modes there are also the following modes. Please select the appropriate mode according to the application.

Working Mode	Application	Advantages
L	Lifting mode	• Suitable attachment speed
B	Breaker mode	• Optimum engine rpm, hydraulic flow
ATT/P	Attachment Power mode	• Optimum engine rpm, hydraulic flow, 2way • Power mode
ATT/E	Attachment Economy mode	• Optimum engine rpm, hydraulic flow, 2way • Economy mode

Consistent High Productivity

One-touch power max. function

Digging force increase for 8.5 seconds of operation when press the left knob switch which is called the one-touch power max. switch and keep pressing. You can normally use E mode to reduce fuel consumption, use this function only when digging power is necessary, temporarily obtain it more than P mode.

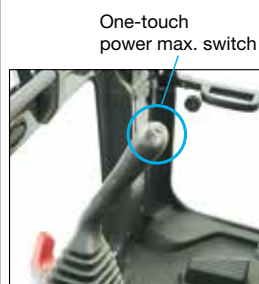
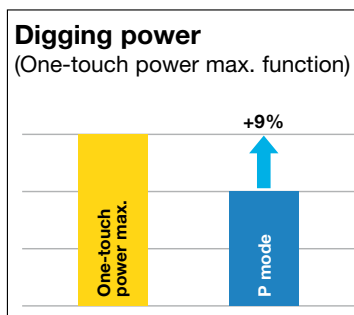

Double pump to improve travel performance

Robustness of the control Double pump system delivers sufficient oil flow for excellent traveling performance. This system also contributes to smooth multi-functional operation of work equipment.

Large fuel tank to increase operating hour

With increased fuel tank capacity, PC130-10M0 can work 25% longer than current machine. Reducing frequent refueling provides more uptime for any jobsites.

Large Maximum Drawbar Pull

Larger maximum drawbar pull provides superb steering and slope climbing performance.

Maximum drawbar pull

122.6 kN (12500 kgf)

DURABILITY & RELIABILITY

High Strength and Reliable Structure

Improve reliability under high temperature

By increasing cooling capacity of oil cooler, reduces possibility of overheating under high temperature.

Oil cooler size

37% up

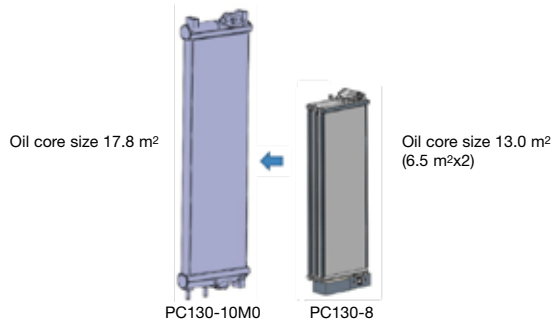

More durable cooling unit

Updated cooling fin and tube shape increase durability. The new structure is also durable against flying stone and fin bending.

Improve heat resistance of main valve O-ring

Reduces possibility of oil leakage under high temperature condition and increases uptime.

Enhanced work equipment

Komatsu thoroughly investigated and analyzed the customer's jobsite and built in working machines with sufficient durability in any application of operation. Designed by state-of-the-art strength analysis technology. Komatsu incorporated an original casting technology in the most loaded part. It is a structure that endured the harsh test. Ultrasonic inspection ensures its quality. Dust resistance was enhanced, incorporating the improvement of the sealing property of the bucket cylinder and of the backlash in the rod.





Rugged revolving frame

Main components are installed to revolving frame. Revolving frame is strengthened to withstand the various ways of severe tests. This tempered frame supports stable operation.



Reliable Komatsu components

All of the major components, such as engine, hydraulic pumps, hydraulic motors and control valves are exclusively designed and manufactured by Komatsu.

Highly reliable electronic devices

Exclusively designed electronic devices have passed severe testing.

- Controllers
- Sensors
- Connectors
- Heat resistant wiring

Sealed connector

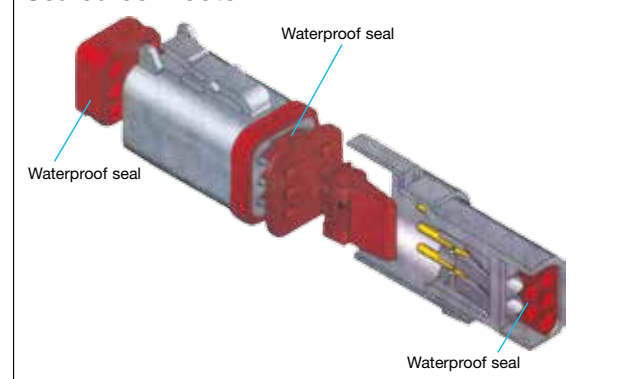

Additional filter to main valve

Add filter to pilot circuit and concentration safety valve and reduce possibility of failure.

EASY MAINTENANCE

Maintenance is Also Part of the Operating Cost. Komatsu Pursued Reduction of Maintenance Time and Cost.

One-piece oil cooler

Newly added single core oil cooler eliminates the space for accumulating dusts and ensures easy cleaning. Single dust-proof net is also easy to detach and reduce cleaning time.



Easy access to filters

Engine oil and fuel system filters are integrated into one side to allow easy maintenance and service.



Swing out A/C capacitor

Easier cleaning of the core by making the automatic air conditioner (A/C) capacitor a hinge structure.



Easy cleaning fuel tank

Adding drain port to the fuel tank that ensures easy and quick cleaning of fuel tank.



Minimization broken of circle grease nipple

The grease nipple of the circle is embedded for protection. It is irrefrangible structure even if wood debris or dusts are coiled around a swing circle.



Easy maintenance time management

The monitor informs replacement time of oil and filters on the LCD when the replacement interval is reached.



Easy to know maintenance time when using breaker

In addition to the above functions, it monitors the breaker usage time. Since the replacement time will be changed depending on the breaker usage time, monitor can notify the optimum replacement time.



Detect abnormality of hydraulic circuit

Clogging sensor for hydraulic oil as standard

When the hydraulic oil filter is clogged, the caution message pops up on the monitor to notify replacing the filter. It is possible to suppress repair cost due to breakdown.



Clogging hydraulic oil filter caution

Cartridge type self pressure reducing valve

Cartridge type valve ensures quick replacement and reducing downtime of control valve failure.

Battery disconnect switch

A battery disconnect switch allows a technician to disconnect the power supply and lock out before servicing or maintenance the machine. Also, minimize discharge of the battery during long-term non operation. System operating lamp tells the timing of disconnect the switch to prevent controller failures.



Fuel filtration

Prepared some filtration systems according to operating environment and region.

Other Features

Improved robustness of the control valve

Blow-by gas sensor, Hydraulic oil clogging sensor Coolant filter

Improved drainability of hydraulic oil and fuel

Easy to check level of hydraulic oil

Fuel line contamination prevention

SAFETY & COMFORT

Safety Should be the First Priority at the Jobsite

Complied with ROPS/OPG level 1

The machine is equipped with a ROPS cab that conforms to ISO 12117-2 for excavators as standard equipment. The ROPS cab has high shock-absorption performance, featuring excellent durability and impact strength. It also satisfies the requirements of OPG top guard level 1 (ISO 10262) for falling objects. Combined with the retractable seat belt, The ROPS cab protects the operator in case of tipping over and against falling objects.



Thermal guard, fan guard

Preventing direct contact to high temperature parts or the finger being caught by fan when checking around the engine, by installing thermal guards and fan guard.

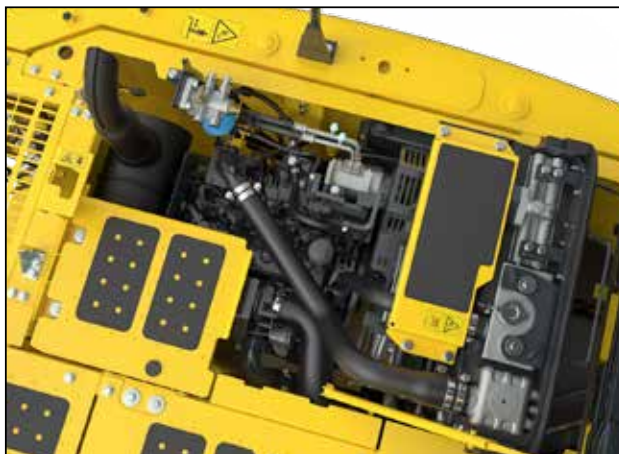

Slip-resistant plates

Highly durable slip-resistant plates to ensure long term superior traction.



Rear view monitor system (Optional)

A new rear view monitor system display has a rear view camera image that is continuously displayed together with the gauges and important vehicle information. This enables the operator to carry out work while easily checking the surrounding area. Even if it is on another screen, it changes to the rear camera image at the same time as the any operation lever is operated.



Cab guard:

- Front half height guard (ISO 10262) (Optional)
- Front full height guard level 2 (ISO 10262) (Optional)
- OPG top guard level 2 (ISO 10262) (Optional)

Lock lever

Pump/Engine room partition

Large side view, rear and sidewise mirrors

Large handrail



Ensuring Operator's Comfort, It Contributes to Increased Safety and Productivity.

Suspension seat

Suspension seat with weight adjustment function as standard equipment. This seat can reduce fatigue even in operation for a long time.

Pressurized cab

Pressurizing inside the cab to minimize the dust entering from outside. It can keep the cab clean.

Low cab noise

With overwhelming low noise, you can operate without stress. Ambient noise is also reduced, reducing the stress of surrounding workers.

Automatic air conditioner

It adjusts automatically to a comfortable temperature throughout the year, even in hot and cold areas.

Low vibration with cab damper mounting

The cab damper mounting combined with high rigidity deck aids vibration reduction at the operator seat.

Sun roller blind (Optional)

Prepared a roller blind which blocks strong sunlight. Reduce sunlight at any time of day.



AUX



The location may change

12 V power supply

Magazine box

Cool & hot box

Luggage box



LARGE HIGH RESOLUTION LCD MONITOR



Large Multi-lingual High Resolution LCD Monitor

A large user-friendly high resolution LCD color monitor enables safe, accurate and smooth work. Simple and easy to operate switches. Function keys facilitate multi-function operations. Displays data in 15 languages to globally support operators around the world.

Indicators

- | | |
|-----------------------------------|--------------------------|
| 1 Auto-decelerator | 6 Fuel gauge |
| 2 Working mode | 7 ECO gauge |
| 3 Travel speed | 8 Fuel consumption gauge |
| 4 Engine water temperature gauge | 9 Function switches menu |
| 5 Hydraulic oil temperature gauge | 10 Language select |

Basic operation switches

- | | |
|-------------------------|-----------------|
| 1 Auto-decelerator | 4 Buzzer cancel |
| 2 Working mode selector | 5 Wiper |
| 3 Traveling selector | 6 Window washer |

Supports Efficient Operation

The main screen displays advices for promoting energy-saving operations as needed. The operator can use the ECO guidance menu to check the operation records, ECO guidance records, average fuel consumption logs, etc.



ECO guidance



ECO guidance menu



ECO guidance records

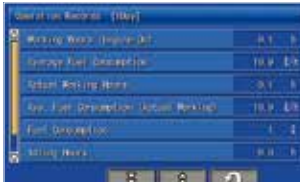

Operation records



Average fuel consumption logs

Simplified Selection of Languages and New Languages added.

It supports 15 languages including newly added languages. Language selection has become extremely easy.

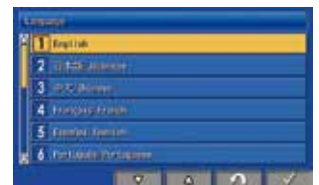

Equipment Management Monitoring System

Monitor function

Controller monitors engine oil level, coolant temperature, battery charge air clogging, etc. If the controller finds any abnormality, it is displayed on the LCD.

Maintenance function

The monitor informs replacement time of oil and filters on the LCD when the replacement interval is reached.

Trouble data memory function

Monitor stores abnormalities for effective troubleshooting.

KOMTRAX

The Komatsu remote monitoring and management technology provides insightful data about your equipment and fleet in user-friendly format.

Energy Saving Operation Report

KOMTRAX delivers the energy-saving operation report based on the operating information such as fuel consumption, load summary and idling time, which helps you efficiently run a business.



This report image is an example of hydraulic excavator

Equipment Management Support

Through the web application, a variety of search parameters are available to quickly find information about specific machines based on key factors. Moreover, KOMTRAX finds out machines with problems from your fleet and shows you through an optimal interface.



Location



Working status

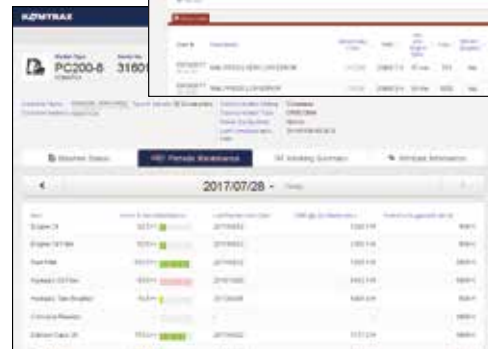

Periodic maintenance

The report contents and data depend on the machine model.





Optimal Strategy for Efficient Work

The detailed information that KOMTRAX puts at your fingertips helps you manage your fleet conveniently on the web anytime, anywhere. It gives you the power to make better daily and long-term strategic decisions.



KOMATSU BRAND BUCKET

KOMATSU Brand Bucket for General Purpose with Wide Bucket Width Category and Feature

Category	Load / Wear / Soil (Application)	Image
General Purpose GP	<p>Load Machine power is mostly medium, but occasionally high. Bucket movements are smooth with minor shock load. Bucket penetrates easily.</p> <p>Wear Material is lightly abrasive. Some sand may be medium abrasive.</p> <p>Soil Mostly loose sand, gravel and finely broken materials.</p>	 
Light Duty LD	<p>Load Machine power remains low during the majority of the work. No impact load.</p> <p>Wear Material is not abrasive.</p> <p>Soil Dirt, loam and clay.</p>	 

Bucket Line-up

Category	Capacity (SAE/CECE) (m ³)	Width *1 (mm)	Weight *1 (kg)	Tooth Quantity	Arm Length		Tooth Type	
					2500 mm	3000 mm	Vertical	Horizontal
GP	0.36/0.33	700	330	4	○	○	-	✓
	0.50/0.45	859	400	4	○	□*2	-	✓
LD	0.63/0.55	1000	440	5	□	□*2	-	✓

○: Density up to 1.8 t/m³ □: Density up to 1.4 t/m³ ×: Not usable ✓: Selectable
*1: Except Side Cutters *2: Limited to light duty usage

OPTIONS

Blade

Items	Wide blade	strengthened blade
		4NH02
Edge type	Welded cutting edge	B.O.C. *1
Width (mm)	2590	2490

*1: Bolt on Cutting Edge



Rain visor



Rear working light



Forest net



Track frame undercover



SPECIAL SPEC.

Attachment Piping Specification

Equips PC130-10M0 for breaker and crusher installation. Hydraulic flow rate can be regulated by setting Breaker Mode on monitor panel during breaker operation.



Super Long Front (Developing, Coming soon)

Super long front attachment boasts a huge digging reach. An excavator with this attachment highly improves working efficiency in various works such as river conservation, lake dredging, slope finishing and materials carrying where an extensively long reach is required.

Main Specification

	PC130-10M0
Reach	12.3 m
Bucket Capacity	0.28 m ³
Boom Length	6900 mm
Arm Length	4900 mm



ATTACHMENT

Komatsu Genuine Attachment Tool

Komatsu-recommended attachment tools for hydraulic excavators

A wide range of attachment tools are provided to suit customers' specific applications.

Hydraulic breaker

The hydraulic breaker is an attachment tool used for crushing rock beds and paved surfaces, demolishing concrete structures, etc. The large gas chamber, ideal gas pressure ratio, and long-stroke piston deliver a powerful impact force. Since the breaker unit does not require an accumulator, the number of parts has been reduced, resulting in lower maintenance costs.



Crusher

This attachment tool is used for demolishing concrete structures. Since it does not have a striking mechanism and features low noise and low vibration, it is suitable for work in urban areas. The open-close cylinder is equipped with a speed-up valve for increasing work speed.



Primary crusher

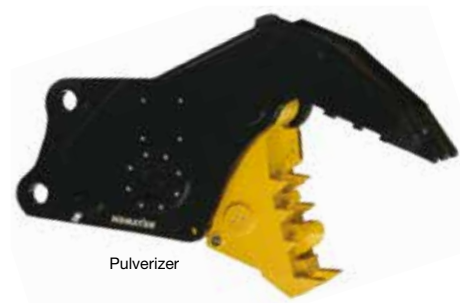

Pulverizer



Applications of Attachment Tools

Application/ Attachment Tool	Civil Engineering	Quarry	Demolition	Industrial Waste Disposal	Iron-Making	Utility Construction	Rental
Hydraulic Breaker	○	○	○	○	○	○	○
Crusher (Primary Crusher)			○				○
Crusher (Pulverizer)			○	○			○

KOMATSU TOTAL SUPPORT



Komatsu Total Support

Komatsu Distributer is ready to provide variety of support before and after procuring machine to keep customers machine available and minimize operation cost.

Fleet recommendation

Komatsu Distributer can study customer job site and provide the most optimum fleet recommendation with detailed information to meet all of your application needs when you are considering to buy new machines or to replace the existing ones from Komatsu.

Product support

Komatsu Distributer secure the quality of machine by offering quality repair and maintenance services to the customer using Komatsu developed programs.

- Preventive Maintenance (PM) Clinic
- Komatsu Oil and Wear Analysis (KOWA)
- Undercarriage inspection service, etc.

Genuine parts and genuine oil

Komatsu Distributer will promptly and smoothly offer genuine parts and genuine oil guaranteed quality to various jobsites. Genuine oil is developed by Komatsu so that it is best matched for our Komatsu engines and hydraulic components. It maximizes engine and hydraulic components performance and prolong life.

Service contract

Komatsu Distributer offers several service package of repair and maintenance for a contracted period with optimum cost. Customer can be "worry-free" by trusting Komatsu Distributer skilled service.

Extended warranty

Extended warranty with several options available. Komatsu guarantee skilled repair with genuine parts and protection from unexpected expenses.

Operator training

Komatsu Distributer can provide excellent operator training which enables them to operate machine safely & efficiently and to maintain machine properly.

SPECIFICATION



ENGINE

Model Komatsu SAA4D95LE-5
 Type Water-cooled, 4-cycle, direct injection
 Aspiration Turbocharged, aftercooled
 Number of cylinders 4
 Bore 95 mm
 Stroke 115 mm
 Piston displacement 3.26 L
 Horsepower:
 SAE J1995 Gross 72.6 kW 97.3 HP
 ISO 9249 / SAE J1349 Net 69.7 kW 93.4 HP
 Rated rpm 2200 min⁻¹
 Fan drive method for radiator cooling Mechanical
 Governor All-speed control, electronic
 EU Stage 3A emission equivalent..



HYDRAULICS

Type HydraMind (Hydraulic Mechanical Intelligence New Design) system, closed-center system with load sensing valves and pressure compensated valves
 Number of selectable working modes 6
 Main pump:
 Type Variable displacement piston type
 Pumps for Boom, arm, bucket, swing, and travel circuits
 Maximum flow 259 L/min
 Supply for control circuit Self-reducing valve
 Hydraulic motors:
 Travel 2 x axial piston motor with parking brake
 Swing 1 x axial piston motor with swing holding brake
 Relief valve setting:
 Implement circuits 31.9 MPa 325 kgf/cm²
 Travel circuit 34.8 MPa 355 kgf/cm²
 Swing circuit 27.1 MPa 276 kgf/cm²
 Pilot circuit 3.2 MPa 33 kgf/cm²
 Hydraulic cylinders:
 (Number of cylinders – bore x stroke x rod diameter)
 Boom 2–105 mm x 995 mm x 70 mm
 Arm 1–115 mm x 1175 mm x 75 mm
 Bucket 1–95 mm x 885 mm x 65 mm



DRIVES AND BRAKES

Steering control Two levers with pedals
 Drive method Hydrostatic
 Maximum drawbar pull 122.6 kN 12500 kgf
 Gradeability 70%, 35°
 Maximum travel speed: High 5.5 km/h
 Low 2.9 km/h
 Service brake Hydraulic lock
 Parking brake Mechanical disc brake



SWING SYSTEM

Drive method Hydrostatic
 Swing reduction Planetary gear
 Swing circle lubrication Grease-bathed
 Service brake Hydraulic lock
 Holding brake/Swing lock Mechanical disc brake
 Swing speed 11.0 min⁻¹



UNDERCARRIAGE

Center frame X-frame
 Track frame Box-section
 Seal of track Sealed track
 Track adjuster Hydraulic
 Number of shoes (Each side) 43
 Number of carrier rollers (Each side) 1
 Number of track rollers (Each side) 7



COOLANT AND LUBRICANT CAPACITY (REFILLING)

Fuel tank 218 L
 Coolant 10.2 L
 Engine 12.5 L
 Final drive (Each side) 2.1 L
 Swing drive 2.5 L
 Hydraulic tank 90 L



OPERATING WEIGHT (APPROXIMATE)

Operating weight including 4600 mm one-piece boom, 2500 mm arm, ISO 7451 heaped 0.50 m³ backhoe bucket, rated capacity of lubricants, coolant, full fuel tank, operator, and standard equipment.

Shoes	Operating Weight	Ground Pressure
500 mm	12700 kg	39.6 kPa 0.40 kgf/cm ²
600 mm	12950 kg	33.5 kPa 0.34 kgf/cm ²
700 mm	13150 kg	29.1 kPa 0.30 kgf/cm ²



DIMENSIONS

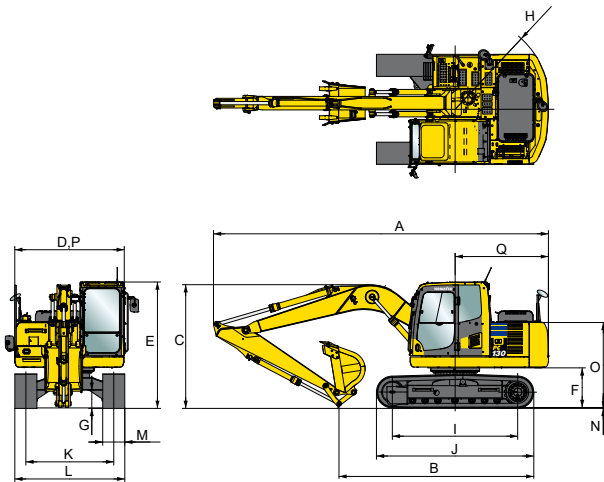

Arm Length	2500 mm	3000 mm
A Overall length	7590 mm	7485 mm
B Length on ground (Transport)	4410 mm	4280 mm
C Overall height (To top of boom)	2875 mm	3185 mm
D Overall width	2500 mm	
E Overall height (To top of cab)	2855 mm	
F Ground clearance, counterweight	895 mm	
G Ground clearance (Minimum)	400 mm	
H Tail swing radius	2190 mm	
I Track length on ground	2880 mm	
J Track length	3610 mm	
K Track gauge	1990 mm	
L Width of crawler	2490 mm	
M Shoe width	500 mm	
N Grouser height	20 mm	
O Machine cab height	1925 mm	
P Machine cab width	2500 mm	
Q Distance, swing center to rear end	2110 mm	



WORKING RANGE

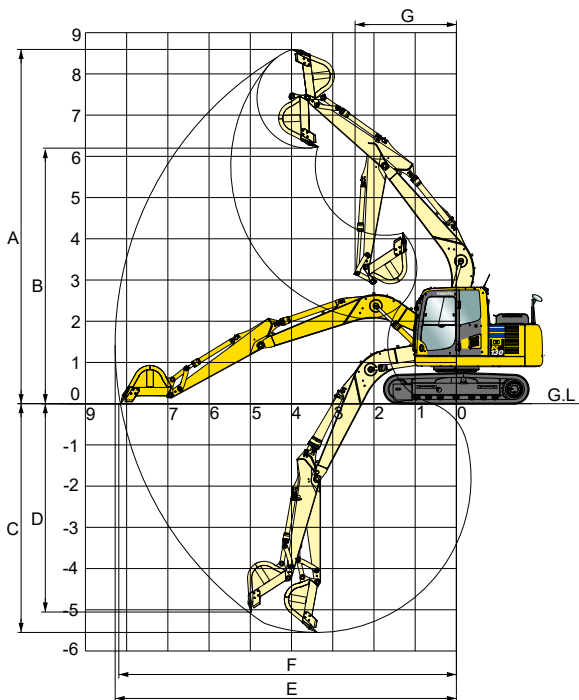

Arm Length	2500 mm	3000 mm	
A Max. digging height	8650 mm	8930 mm	
B Max. dumping height	6210 mm	6615 mm	
C Max. digging depth	5520 mm	5955 mm	
D Max. vertical wall digging depth	4980 mm	5365 mm	
E Max. digging reach	8290 mm	8720 mm	
F Max. digging reach at ground level	8170 mm	8595 mm	
G Min. swing radius	2450 mm	2620 mm	
SAE 1179 Rating	Bucket digging force at power max.	80.9 kN 8250 kgf	80.9 kN 8250 kgf
	Arm crowd force at power max.	64.5 kN 6580 kgf	56.8 kN 5800 kgf
ISO 6015 Rating	Bucket digging force at power max.	93.4 kN 9520 kgf	93.4 kN 9520 kgf
	Arm crowd force at power max.	67.5 kN 6880 kgf	59.3 kN 6050 kgf

Major Component Weights

Items		Weight for a Machine (kg)	
Boom (Include piping, Pins, Arm cylinder)	4.6 m	Without ATT Piping	930
		With 1 ATT Piping	970
Arm (Include piping, Pins, Bucket cylinder)	2.5 m	Without ATT Piping	430
		With 1 ATT Piping	460
		HD Without ATT Piping	500
		HD With 1 ATT Piping	540
	3.0 m	Without ATT Piping	550
		With 1 ATT Piping	580
Bucket (Without linkage)	0.36 m ³ GP	330	
	0.50 m ³ GP	400	
	0.63 m ³ LD	440	
Roller Guards	Optional	25	
Shoe Assembly (With Link)	500 mm	1450	
	600 mm	1630	
	700 mm	1810	

Standard Specification:

Operating weight: PC130-10M0: 12700 kg

Operating weight including below spec.

Boom: 4600 mm Standard

Arm: 2500 mm Standard

Bucket: 0.50 m³ GP

Shoe: 500 mm triple grouser

Counter weight: Standard

Rated capacity of lubricants, coolant, full fuel tank, 80 kg operator.



LIFTING CAPACITY WITH LIFTING MODE

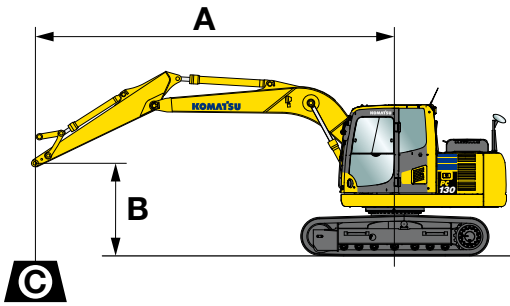

PC130-10M0

- A: Reach from swing center
- B: Arm top pin height
- C: Lifting capacity
- Cf: Rating over front
- Cs: Rating over side
- ⊗: Rating at maximum reach

PC130-10M0 Boom: 4600 mm Arm: 2500 mm Shoe: 500 mm triple grouser													
B	A	⊗ MAX		7.6 m		6.1 m		4.6 m		3.0 m		1.5 m	
		Cf	Cs	Cf	Cs	Cf	Cs	Cf	Cs	Cf	Cs	Cf	Cs
7.6 m													
6.1 m		*2750 kg	*2750 kg					*3700 kg	3700 kg				
4.6 m		*2500 kg	2200 kg			3250 kg	2350 kg	*3850 kg	3650 kg				
3.0 m		*2500 kg	1900 kg			3200 kg	2300 kg	*4600 kg	3500 kg	*6350 kg	*6350 kg		
1.5 m		2500 kg	1800 kg			3100 kg	2200 kg	4750 kg	3300 kg	*8900 kg	6100 kg		
0 m		2550 kg	1800 kg			3050 kg	2150 kg	4600 kg	3150 kg	*7150 kg	5800 kg		
-1.5 m		2850 kg	2000 kg			3050 kg	2100 kg	4550 kg	3100 kg	*9250 kg	5800 kg	*5050 kg	*5050 kg
-3.0 m		3600 kg	2500 kg					4550 kg	3100 kg	*7750 kg	5850 kg	*9200 kg	*9200 kg

PC130-10M0 Boom: 4600 mm Arm: 3000 mm Shoe: 500 mm triple grouser													
B	A	⊗ MAX		7.6 m		6.1 m		4.6 m		3.0 m		1.5 m	
		Cf	Cs	Cf	Cs	Cf	Cs	Cf	Cs	Cf	Cs	Cf	Cs
7.6 m		*2750 kg	*2750 kg										
6.1 m		*2250 kg	*2250 kg										
4.6 m		*2050 kg	1900 kg			3250 kg	2950 kg	*3350 kg	*3350 kg				
3.0 m		*2050 kg	1650 kg			3200 kg	2250 kg	*4150 kg	3500 kg	*5300 kg	*5300 kg		
1.5 m		*2100 kg	1550 kg			3100 kg	2150 kg	4750 kg	3300 kg	*8050 kg	6200 kg		
0 m		2250 kg	1600 kg			3000 kg	2100 kg	4550 kg	3100 kg	*7800 kg	5750 kg		
-1.5 m		2500 kg	1750 kg			2950 kg	2050 kg	4450 kg	3000 kg	9200 kg	5650 kg	*4450 kg	*4450 kg
-3.0 m		3000 kg	2100 kg					4450 kg	3000 kg	*8350 kg	5700 kg	*7600 kg	*7600 kg
-4.6 m		*3450 kg	3350 kg							*5550 kg	*5550 kg		

* Load is limited by hydraulic capacity rather than tipping. Ratings are based on ISO standard No. 10567 rated load do not exceed 87% of hydraulic lift capacity or 75% of tipping load.



LIFTING CAPACITY WITH LIFTING MODE

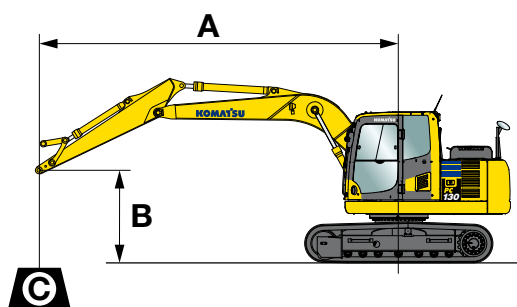

PC130-10M0

- A: Reach from swing center
- B: Arm top pin height
- C: Lifting capacity
- Cf: Rating over front
- Cs: Rating over side
- ⊗: Rating at maximum reach

PC130-10M0 Boom: 4600 mm Arm: 2500 mm Shoe: 600 mm triple grouser													
B	A	⊗ MAX		7.6 m		6.1 m		4.6 m		3.0 m		1.5 m	
		Cf	Cs	Cf	Cs	Cf	Cs	Cf	Cs	Cf	Cs	Cf	Cs
7.6 m													
6.1 m		*2750 kg	*2750 kg					*3700 kg	3700 kg				
4.6 m		*2500 kg	2250 kg			3300 kg	2350 kg	*3850 kg	3700 kg				
3.0 m		*2500 kg	1900 kg			3250 kg	2300 kg	*4600 kg	3500 kg	*6350 kg	*6350 kg		
1.5 m		2550 kg	1800 kg			3150 kg	2250 kg	4850 kg	3350 kg	*8900 kg	6150 kg		
0 m		2600 kg	1850 kg			3100 kg	2150 kg	4650 kg	3200 kg	*7150 kg	5900 kg		
-1.5 m		2900 kg	2000 kg			3050 kg	2150 kg	4600 kg	3150 kg	*9250 kg	5850 kg	*5050 kg	*5050 kg
-3.0 m		3650 kg	2550 kg					4650 kg	3150 kg	*7750 kg	5950 kg	*9200 kg	*9200 kg

PC130-10M0 Boom: 4600 mm Arm: 3000 mm Shoe: 600 mm triple grouser													
B	A	⊗ MAX		7.6 m		6.1 m		4.6 m		3.0 m		1.5 m	
		Cf	Cs	Cf	Cs	Cf	Cs	Cf	Cs	Cf	Cs	Cf	Cs
7.6 m		*2750 kg	*2750 kg										
6.1 m		*2250 kg	*2250 kg										
4.6 m		*2050 kg	1950 kg			3300 kg	2350 kg	*3350 kg	*3350 kg				
3.0 m		*2050 kg	1700 kg			3250 kg	2300 kg	*4150 kg	3550 kg	*5300 kg	*5300 kg		
1.5 m		*2100 kg	1600 kg			3150 kg	2200 kg	4850 kg	3300 kg	*8050 kg	6250 kg		
0 m		2300 kg	1600 kg			3050 kg	2100 kg	4600 kg	3150 kg	*7800 kg	5850 kg		
-1.5 m		2500 kg	1750 kg			3000 kg	2050 kg	4500 kg	3050 kg	9350 kg	5750 kg	*4450 kg	*4450 kg
-3.0 m		3050 kg	2100 kg					4550 kg	3050 kg	*8350 kg	5800 kg	*7600 kg	*7600 kg
-4.6 m		*3450 kg	3400 kg							*5550 kg	*5550 kg		

* Load is limited by hydraulic capacity rather than tipping. Ratings are based on ISO standard No. 10567 rated load do not exceed 87% of hydraulic lift capacity or 75% of tipping load.



LIFTING CAPACITY WITH LIFTING MODE

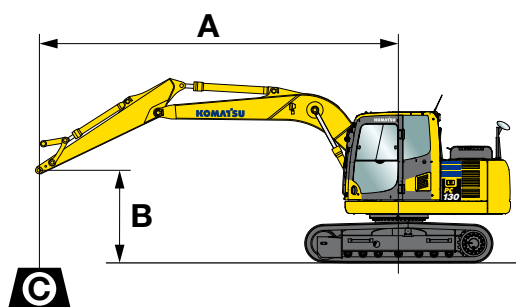

PC130-10M0

- A: Reach from swing center
- B: Arm top pin height
- C: Lifting capacity
- Cf: Rating over front
- Cs: Rating over side
- ⊗: Rating at maximum reach

PC130-10M0 Boom: 4600 mm Arm: 2500 mm Shoe: 700 mm triple grouser													
B	A	⊗ MAX		7.6 m		6.1 m		4.6 m		3.0 m		1.5 m	
		Cf	Cs	Cf	Cs	Cf	Cs	Cf	Cs	Cf	Cs	Cf	Cs
7.6 m													
6.1 m		*2750 kg	*2750 kg					*3700 kg	*3700 kg				
4.6 m		*2500 kg	2250 kg			3350 kg	2400 kg	*3850 kg	3750 kg				
3.0 m		*2500 kg	1950 kg			3300 kg	2350 kg	*4600 kg	3550 kg	*6350 kg	*6350 kg		
1.5 m		2600 kg	1850 kg			3200 kg	2250 kg	4900 kg	3350 kg	*8900 kg	6250 kg		
0 m		2650 kg	1850 kg			3150 kg	2200 kg	4750 kg	3200 kg	*7150 kg	5950 kg		
-1.5 m		2900 kg	2050 kg			3100 kg	2150 kg	4650 kg	3150 kg	*9250 kg	5950 kg	*5050 kg	*5050 kg
-3.0 m		3700 kg	2600 kg					4700 kg	3200 kg	*7750 kg	6000 kg	*9200 kg	*9200 kg

PC130-10M0 Boom: 4600 mm Arm: 3000 mm Shoe: 700 mm triple grouser													
B	A	⊗ MAX		7.6 m		6.1 m		4.6 m		3.0 m		1.5 m	
		Cf	Cs	Cf	Cs	Cf	Cs	Cf	Cs	Cf	Cs	Cf	Cs
7.6 m		*2750 kg	*2750 kg										
6.1 m		*2250 kg	*2250 kg										
4.6 m		*2050 kg	1950 kg			*3350 kg	2400 kg	*3350 kg	*3350 kg				
3.0 m		*2050 kg	1700 kg			3300 kg	2350 kg	*4150 kg	3600 kg	*5300 kg	*5300 kg		
1.5 m		*2100 kg	1600 kg			3200 kg	2250 kg	4900 kg	3350 kg	*8050 kg	6350 kg		
0 m		*2350 kg	1650 kg			3100 kg	2150 kg	4700 kg	3200 kg	*7800 kg	5900 kg		
-1.5 m		2550 kg	1750 kg			3050 kg	2100 kg	4600 kg	3100 kg	*9450 kg	5800 kg	*4450 kg	*4450 kg
-3.0 m		3100 kg	2150 kg					4600 kg	3100 kg	*8350 kg	5850 kg	*7600 kg	*7600 kg
-4.6 m		*3450 kg	*3450 kg							*5550 kg	*5550 kg		

* Load is limited by hydraulic capacity rather than tipping. Ratings are based on ISO standard No. 10567 rated load do not exceed 87% of hydraulic lift capacity or 75% of tipping load.



STANDARD EQUIPMENT

ENGINE

- Automatic engine warm-up system
- Coolant filter
- Dry type air cleaner, double element
- Engine, Komatsu SAA4D95LE-5
- Engine overheat prevention system
- Radiator and oil cooler dust proof net
- Suction fan

ELECTRICAL SYSTEM

- Alternator, 24 V/60 A
- Auto-decelerator
- Batteries, 2 X 12 V/64 Ah
- Battery disconnect switch with operation lamp
- Starting motor, 24 V/4.5 kW
- Working light, 2 (Boom and RH)

HYDRAULIC SYSTEM

- Boom holding valve
- Clogging sensor for hydraulic oil return
- Power maximizing system

- Pressure Proportional Control (PPC) hydraulic control system
- Working mode selection system

GUARDS AND COVERS

- Fan guard structure

UNDERCARRIAGE

- Hydraulic track adjusters (Each side)
- Track roller
 - 7 each side
- Track shoe
 - 500 mm triple grouser

OPERATOR ENVIRONMENT

- 12 V power supply
- Automatic air conditioner with defroster
- AM/FM radio
- AUX
- Equipment Management Monitoring System
- Front underview mirror

- Large multi-lingual high resolution LCD monitor
- Lock lever
- Operator protective top guard, OPG level 1 (ISO 10262)
- Rear view mirrors (RH, LH, rear, side-wise)
- ROPS cab (ISO 12117-2)
- Suspension seat

OTHER EQUIPMENT

- Blow-by sensor
- Counterweight
- Electric horn
- KOMTRAX (Only for approved area)
- Rear reflector
- Seat belt, retractable
- Slip-resistant plates
- Travel alarm



OPTIONAL EQUIPMENT

ELECTRICAL SYSTEM

- Batteries, large capacity
- Rear camera
- Working lights
 - 2 on cab
 - 1 on counterweight
 - Beacon lamp

HYDRAULIC SYSTEM

- Service valve

UNDERCARRIAGE:

- Shoes, triple grouser
 - 600 mm
 - 700 mm
- Track frame undercover
- Track roller guards (Center section)

OPERATOR ENVIRONMENT

- Bolt-on top guard, OPG top guard level 2 (ISO 10262)
- Cab accessories
 - Rain visor
 - Sun roller blind
 - Sun visor (for front window only)
- Cab front guard
 - Bolt-on front guard, OPG front guard level 2 (ISO 10262)
 - Half height guard
- Forest net
- Rear view monitor system

WORK EQUIPMENT

- Arms
 - 2500 mm arm assembly
 - 2500 mm HD arm assembly
 - 3000 mm arm assembly
 - 4900 mm arm assembly (for Super Long Front)(Developing, Coming soon)
- Blade assembly (Bolt-on cutting edge type)
- Boom
 - 4600 mm
 - 6900 mm (for Super Long Front) (Developing, Coming soon)
- Wide lade assembly (Welded cutting edge type)

Up to 20% blended biodiesel fuel and paraffine fuel can be used. Please consult your Komatsu distributor for detail.

<https://home.komatsu/en>

Printed in Japan 202011 IP.AD